



**LOEGERING**

# **OWNER'S MANUAL**

**Z SERIES TRACKS**

Rev. 355\_05

**LOEGERING**  
15514 37<sup>th</sup> Street SE  
Casselton, ND 58012 USA  
E-Mail: [lmi@loegering.com](mailto:lmi@loegering.com)

800-373-5441  
701-347-5441  
Fax: 701-347-4323  
Internet: [www.loegering.com](http://www.loegering.com)



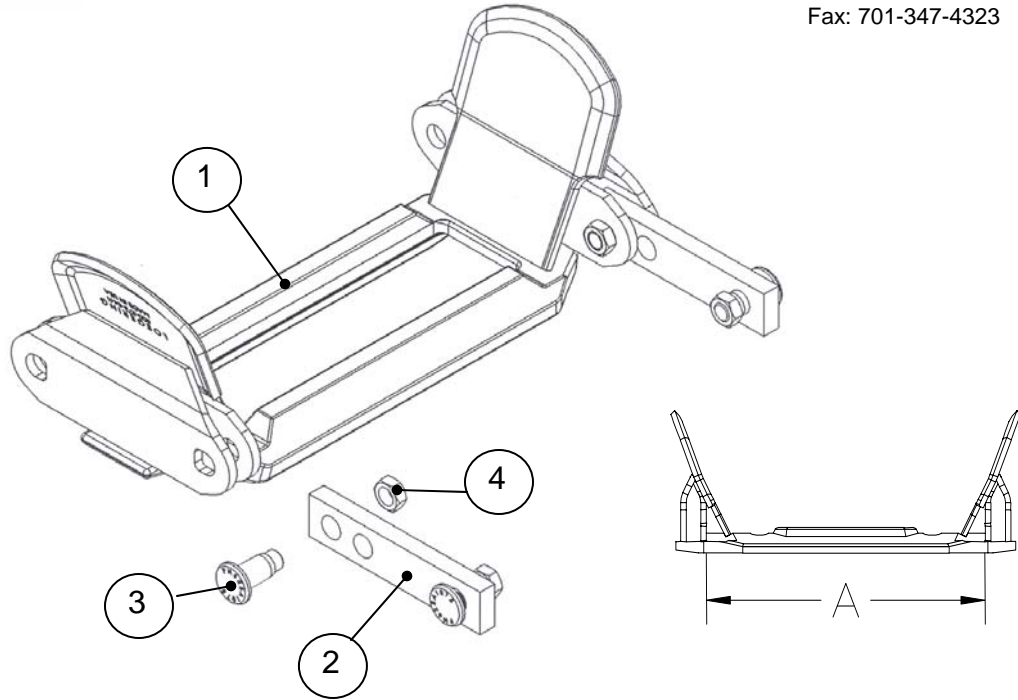

## Z SERIES PARTS LIST

Ref.	Part Number	Weight (LB/KG)	Description
1	600118	17/7.7	Pad Weldment, 11.125", Standard Link Style
1	600120	19/8.6	Pad Weldment, 12.5", Standard Link Style
1	600122	20/9.0	Pad Weldment, 13.25", Standard Link Style
1	600124	21/9.5	Pad Weldment, 13.75", Heavy Duty Link Style
1	600125	24/10.9	Pad Weldment, 15.5", Heavy Duty Link Style
2	FN425	.6/.3	Link, 3 Hole, Standard 1/2"
2	FN424	.8/.4	Link, 3 Hole, Heavy 5/8"
3	400660	.13/.06	Dura Pin, Standard Link Style
3	PN625A1160	.14/.06	Dura Pin, Heavy Link Style
4	PH0171-5CP	.02/.01	Jam Nut, 1/2" NF Gr. 8

**Note:** These track series use Installation Tool P/N S014

A = Pad width: distance between the two inner link plates.



Loeering  
15514 37<sup>th</sup> Street SE  
Casselton, ND 58012 USA  
Ph: 800-373-5441  
Fax: 701-347-4323

## INSTALLING “Z” SERIES TRACKS

**NOTE: Any modifications (welding, cutting, etc.) to machine, tracks, or track accessories without proper authorization will void warranty. See Limited Warranty for further details. Z series track are not recommended for use on solid rubber, foam-filled, segmented, aircraft, and some styles of tires (call Loeering.).**

Every track includes an installation tool (P/N S014).

1. Install idler system or axle assembly for your specific model of equipment.
2. Inflate tires to recommended air pressure - check pressure regularly.
3. Unroll track on a level surface and divide into two equal sections. Tip one track over so side plates are in contact with the ground. Fold first 3 or 4 pads back and drive machine forward until one front tire is positioned between track side plates and just touches pad bottom. Lay pads back onto tire and attach a rope or chain on end pad. Run rope or chain over front and back tires and tuck it under back tire (Diagram 1).

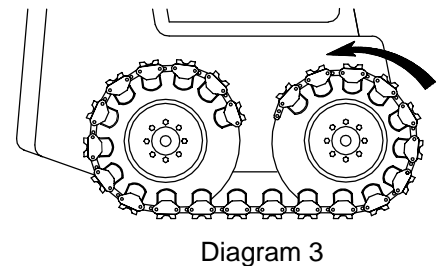
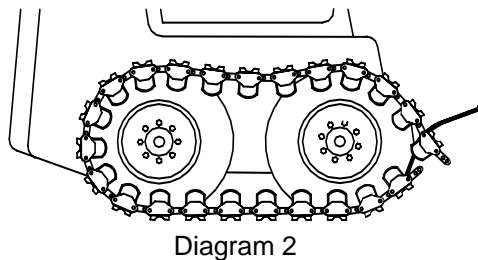
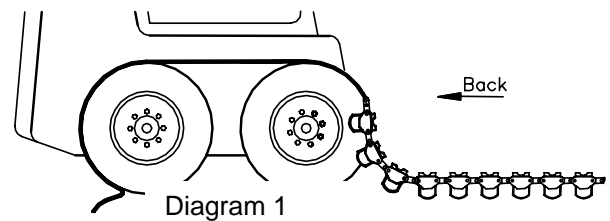

4. While an assistant observes, slowly back machine until track is pulled over, around, and under the tandem wheels. Stop when last pad lifts off ground and is starting to get pulled up front tire. (Diagram 2).
5. Chain or tie ends of track together with installation tool. Continue backing machine until ends of track are between wheels (Diagram 3). Remove chain or rope.
6. Position install tool as shown in diagrams 4 and 5.

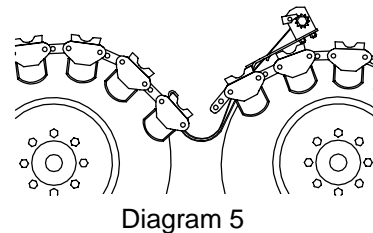
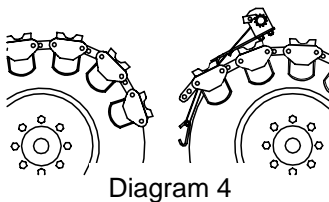

7. Tighten track using a wrench or breaker bar/socket arrangement no longer than 18 inches.

**CAUTION: Use of a tool or cheater bar longer than 18" may result in personal injury or death and will void installation tool warranty.**

It may be necessary to slowly rock machine back and forth while occasionally stopping to tighten track. This will help take up excess slack in the track.

If track appears to be too short: Measure distance "A" at track ends (Diagram 6). Round to next whole number (i.e. 3¼" rounds to 4"). This is the number of link locations to extend; track will be lengthened the same number of inches.

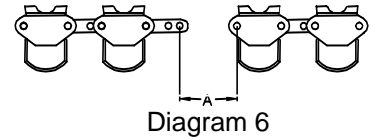

**NOTE:** If multiple links need to be lengthened, it is best to drive out of track and make adjustments on the ground. Torque *Dura Pins* nuts to 80 ft-lbs. ± 5 ft-lbs.

If rounded number is greater than the total number of links in the short position, an additional pad is required. Contact your local dealer or Loegering.

If track appears to be too long: Shorten the track by changing links in the long position to the short position. If all the links are in the short position, remove one pad and continue with procedure for short track (Diagram 6).

To remove a pad section (one pad and two adjoining links): Remove four *Dura Pin* assemblies. For an extremely worn track, it may be necessary to pull adjoining pads together to remove pin. Remove the pad and two adjoining links. Reposition loose track and reinstall two *Dura Pin* assemblies. Torque *Dura Pin* nuts to 80ft-lbs ± 5 ft-lbs. Save remaining parts for later use.

8. To connect ends of track, install *Dura Pins* in links. Torque nuts to 80 ft-lbs. ± 5 ft-lbs.

9. Remove installation tool and slowly drive machine back and forth allowing track to pass through at least two complete revolutions. **Verify that track is not striking machine.** A properly adjusted track must have one to three inches of sag (Diagram 7).

10. Unroll second track and change links to match those of the first track installed.

11. Repeat instructions 3 through 10 for track not yet installed.

12. Return machine to its normal operating configuration.

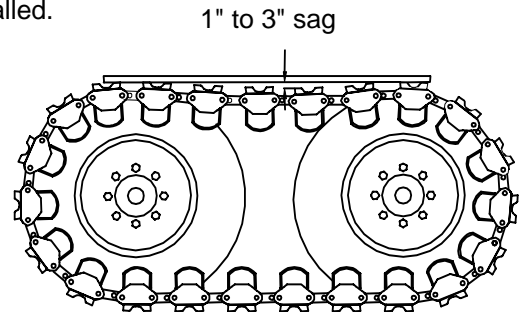

Diagram 7

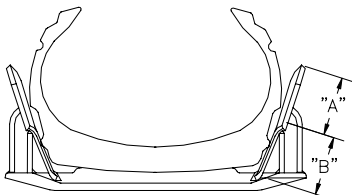

Diagram 8

13. **CHECK TRACK-TO-TIRE FIT:** With tires inflated to maximum recommended air pressure, load machine to normal operating weight. Shut off machine and check track fit (Diagram 8). Area A must not compress tire side wall. Area B may compress corners of tread without any problem. Clearance at both points is acceptable, unless track is able to wander far enough to strike machine.

**NOTE:** Track will require one or more length adjustments during break-in period (dependant upon operator usage).

**See "REMOVING "Z" SERIES TRACKS" for specific removal instructions.**

## REMOVING “Z” SERIES TRACKS

1. **TO AVOID DEATH:** Raise and block boom according to machine manufacturer's instructions, allowing safe access to front of machine. Turn off machine when its operation is not necessary for track removal process.
2. Using a  $\frac{3}{4}$ " wrench or socket set, loosen two nuts on two opposing Dura-pins.  
  
NOTE: For machines with limited clearance, drive forward so nuts can be loosened easily from the front (do not remove the nuts yet). Drive back again to center Dura-pins on top between tires.
3. Feed hook end of installation tool down between pads ahead of loosened Dura-pins, position winch assembly on pad. Position hook on opposing pad. See Diagram 5 of "INSTALLING Z SERIESTRACKS".
4. Using a 1 1/8" wrench or breaker bar/socket arrangement not longer than 18", operate the installation tool until tension is relieved and adjuster link assembly moves freely.

**CAUTION: Use of a tool or cheater bar longer than 18" may result in personal injury or death and will void installation tool warranty.**

6. Remove the two Dura-pins and nuts. Carefully loosen installation tool until track ends lay on tires. Remove installation tool.
7. While an assistant observes from a safe distance, drive machine forward until track can be removed from front tire. Do not allow end of track between tires to go under rear tire. Carefully lower track off the front tire. CAUTION: To avoid injury, do not stand in front of track as it is lowered.
8. Slowly back machine off the track. Repeat procedure for other side.
9. Return machine to normal operating configuration. NOTE: Accessories (wheel spacers, boom stop, etc.) may remain on machine.

## PIN WEAR GAUGE

To determine if the track requires new pins remove a pin and slide the worn area into the gauge located on the winch portion of the installation tool. If the pin slides into the gauge it is time to replace the pins. Contact your dealer for replacement parts.

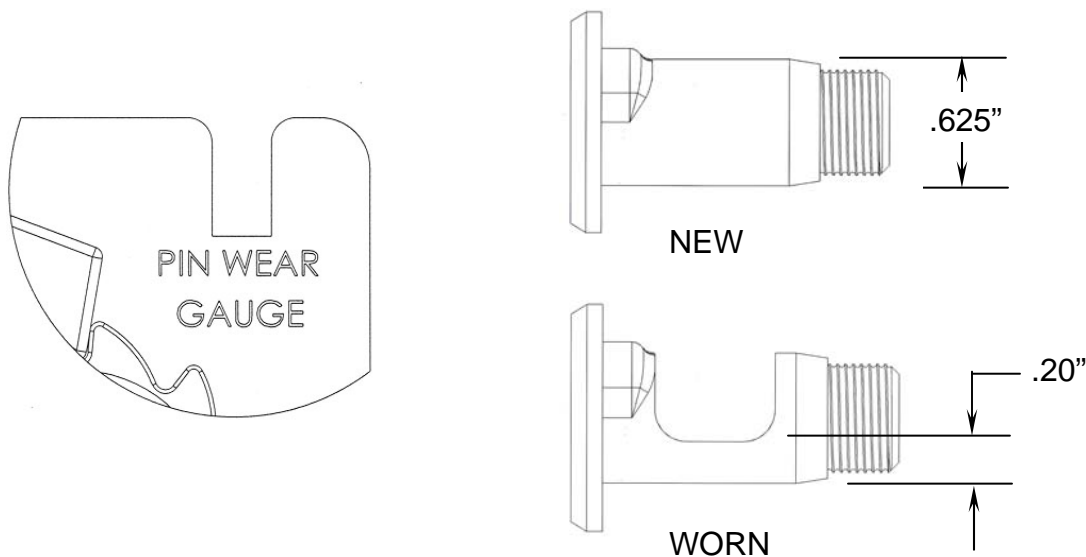

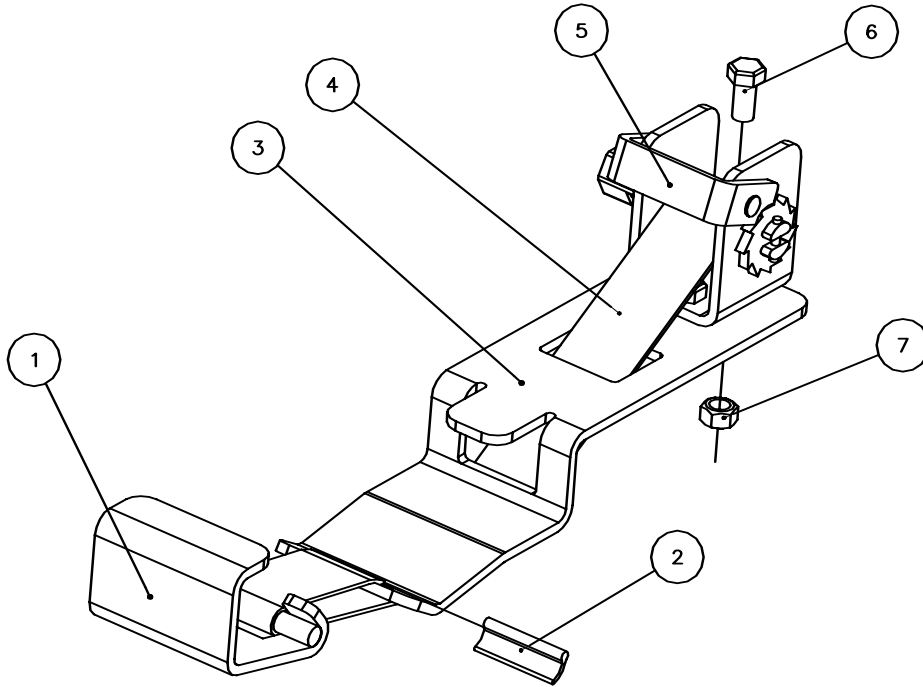

### Z SERIES INSTALLATION TOOL PARTS LIST

ITEM	QTY.	PART NUMBER	DESCRIPTION
-	-	S014	Installation Tool, Z Series
1	1	S012	Hook
2	1	YN607	Wedge
3	1	S017	Base Plate
4	1	YN502	Webbing, 2" x 60"
5	1	YN501	Winch, 2"
6	2	PH0170-1BP	Nut, ½"-13UNC Gr. 5, Plated
7	2	PD0170-1BP	Bolt, ½" -13UNC x 1" Gr. 5, Plated

# WHEEL SPACER INSTALLATION

## INSTALLING SPACERS WITHOUT STUDS

1. Remove wheels and thoroughly clean the hub flange surface of all foreign materials including dirt, grease, loose paint, etc. Failure to remove all foreign material will cause the spacers to become loose resulting in damage to the spacer and/or studs.
2. Inspect spacers for any excessive paint or foreign material prior to installation.
3. Install spacers. Spacer should fit easily on wheel hub - if there is any interference, contact Loegering before reinstalling wheels.
4. Reinstall wheels and torque nuts to the manufacturer's recommended specification.

NOTE: If reach nuts are supplied with the spacers, use them in lieu of the nuts removed from the machine. Save the nuts removed from the machine so that the wheels may be reinstalled when the spacers are removed.

5. Failure to follow these instructions will void the warranty on the spacers.

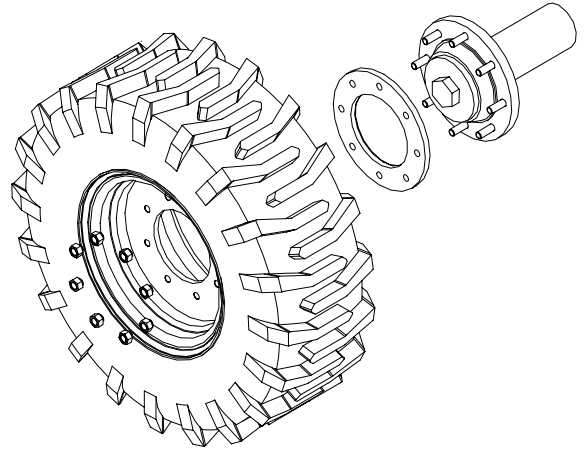

## INSTALLING SPACERS WITH STUDS

1. Remove wheels and thoroughly clean the hub flange surface of all foreign materials including dirt, grease, loose paint, etc. Failure to remove all foreign material will cause the spacers to become loose which will result in damage to the spacer and/or studs.
2. Inspect spacers for any excessive paint or foreign material prior to installation.
3. Install spacers. Spacer should fit easily on wheel hub - if there is any interference, contact Loegering before tightening nuts.
4. Tighten nuts evenly to allow spacer ring to center itself on tapered nuts. Torque  $\frac{1}{2}$ " nuts 85 to 95 ft-lbs.,  $\frac{9}{16}$ " nuts 110 to 130 ft-lbs., and  $\frac{5}{8}$ " nuts 165 to 185 ft-lbs.
5. Reinstall wheels and torque nuts to the manufacturer's recommended specification.
6. Failure to follow these instructions will void the warranty on the spacers.

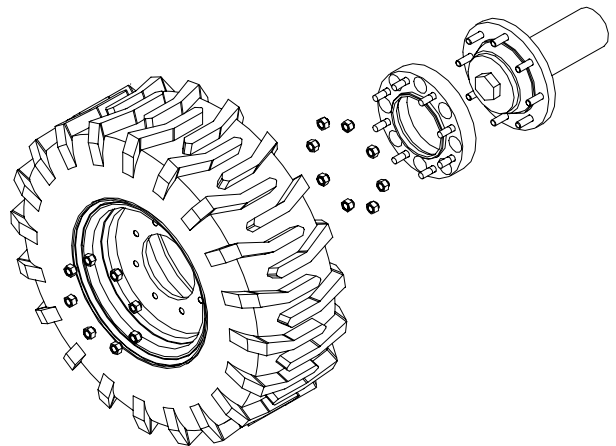

# GUSSET GUARD INSTALLATION INSTRUCTIONS

## MELROE 7753 and 773

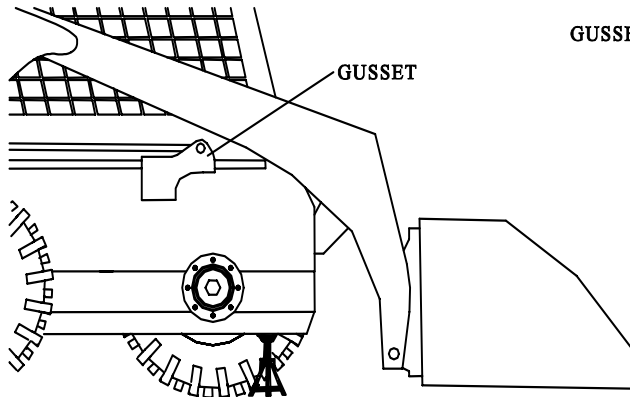

**Figure 1**

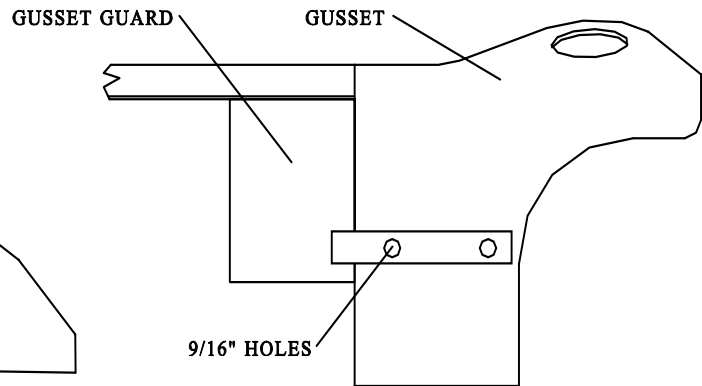

**Figure 2**

Qty.	Part Number	Description
-	LN811	Gusset Guard Assembly
1	LM812	Gusset Guard, Left
1	LM811	Gusset Guard, Right
2	PD0170-1.5BP	1/2"-13UNC x 1 1/2" Bolt
2	PH0170-1BP	1/2"-13UNC Nut
2	PJ0170-3.2BP	1/2" Lock Washer

Step 1. Raise machine, block, and remove right front wheel per machine manufacturer's instruction.

**WARNING:** Failure to use adequate blocking or jack stands could result in injury or death.

**NOTE:** Wheel spacers, if required, should be installed at this time.

Step 2. Position right gusset guard on right gusset such that it is against the gusset and fender as shown in Figure 2.

Step 3. Using a C-clamp or locking pliers clamp the gusset guard firmly in place.

Step 4. Mark the location of the holes.

Step 5. Remove the clamp(s) and gusset guard.

Step 6. Drill two 9/16" diameter holes. (Holes are 3½" on center)

Step 7. Reposition gusset guard. Insert bolts so that the nuts will be inside the gusset. Install lock washers and nuts (supplied). Torque to 70 to 80 ft-lbs.

Step 8. Replace wheel and repeat process for the left side of the machine.



Loeering  
15514 37<sup>th</sup> Street SE  
Casselton, ND 58012 USA  
Ph: 800-373-5441  
Fax: 701-347-4323

## LIMITED WARRANTY AND DISCLAIMER OF WARRANTIES

Loeering Mfg. Inc. warrants its Z Series tracks against operational failures caused by defective material or workmanship, which occur during normal use within fifteen (15) months from the date of purchase or twelve (12) months from the date the product is first put into service, whichever is earlier. Your sole remedy under this Warranty is repair or replacement of the Z Series tracks that are determined by Loeering Mfg. Inc. to be defective in material or workmanship. Any modifications (welding, cutting, etc.) to the machine, tracks, or track accessories without proper authorization will void the warranty. Written authorization for any return of goods on a warranty claim must first be obtained from Loeering Mfg. Inc. All returns must be accompanied by a Returned Material Authorization Number (RMA #) and a written explanation of claimed defects with the exact circumstances of operational failure. Any product returned for warranty inspection must be shipped prepaid and will be returned freight collect. All costs of product removal and product installation are at the customer's expense. Loeering Mfg. Inc. does not warrant that its Z Series tracks will meet your requirements, nor does it assume responsibility for costs and/or damages resulting from use. Since tire size often varies from the stated size, the customer is solely responsible for checking track-to-tire fit and/or providing proper clearance and safety shielding. There are no other warranties. **THE ABOVE WARRANTY IS EXCLUSIVE AND IN LIEU OF AND TO THE EXCLUSION OF ALL OTHER WARRANTIES, WHETHER EXPRESS OR IMPLIED, INCLUDING THE IMPLIED WARRANTIES OF MERCHANTABILITY, FITNESS FOR A PARTICULAR PURPOSE, AND NON-INFRINGEMENT. NO ORAL OR WRITTEN INFORMATION OR ADVICE GIVEN BY LOEGERING MFG. INC., ITS EMPLOYEES, OR DEALERS SHALL ALTER, MODIFY, OR INCREASE THE SCOPE OF THE ABOVE WARRANTY OR CREATE ANY NEW WARRANTIES.** Some states do not allow the exclusion of implied warranties, so the above exclusion may not apply to you. In that event, any implied warranties are limited in duration to ninety (90) days from the date of delivery of our Z Series tracks. This Warranty gives you specific legal rights. You may have other rights, which vary from state to state.

## LIMITATIONS OF REMEDIES

Loeering Mfg. Inc.'s entire liability and your exclusive remedies shall be repair or replacement of the Z Series tracks for any alleged breach, failure, or malfunction. Regardless of whether any remedy set forth herein fails of its essential purpose, in no event will Loeering Mfg. Inc. be liable to you for any special, consequential, indirect, or similar damages, including any claimed damage to person (except in the case of consumer goods) or other property, any lost time, or lost profits arising out of the use or inability to use the Z Series tracks. Some states do not allow limitation or exclusion of liability for incidental or consequential damages, so the above limitation or exclusion may not apply to you.

