



# Grader Rake



PALADIN LIGHT CONSTRUCTION

## FEATURES:

- Tines increase digging action for grading and separates debris for site clean-up
- Scarifies and levels hard-packed soil when grading
- Increases productivity over conventional rakes by operating in a forward direction
- Features a full-floating design to follow compound grades; oscillates from side to side for crowning roads
- 1 year warranty on structure  
6 month warranty on hydraulics

Model LAF6692 Shown



# Grader Rake

## FEATURES:

- Tines increase digging action for grading and separates debris for site clean-up
- Scarifies and levels hard-packed soil when grading
- Increases productivity over conventional rakes by operating in a forward direction
- Features a full-floating design to follow compound grades; oscillates from side to side for crowning roads

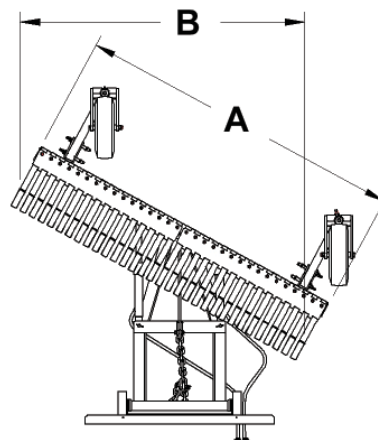

Model	Weight (Approx.)	Width (OD) A	Cutting Width		Height C	Depth D
			Straight	Max. Angle B*		
<b>Standard Grade: Designed for skid-steer loaders</b>						
LAF6682	700 lbs	82"	81-1/2"	71-5/8"	33"	72"
LAF6692	750 lbs	92"	91-3/4"	80-5/8"	33"	72"
LAF6697	800 lbs	97"	97"	85-1/4"	33"	72"
LAF6602	850 lbs	102"	102-1/8"	89-3/4"	33"	72"
<b>Construction Grade: Designed for wheel loaders &amp; backhoe loaders</b>						
LAF6696	900 lbs	97"	97"	86-1/4"	33"	72"
LAF6608	950 lbs	108"	107-1/4"	95-3/8"	33"	72"
LAF6618	1025 lbs	116"	117-5/8"	104-5/8"	33"	72"

\*Standard Grade Max. Angle: 28.5°

\*Construction Grade Max. Angle: 27.2°

### Standard Grade

#### **Carrier Specifications:**

lift capacities < 9,000 lbs.  
operating weight < 11,000 lbs.

### Construction Grade

#### **Carrier Specifications:**

lift capacities < 10,000 lbs.  
operating weight < 20,000 lbs.

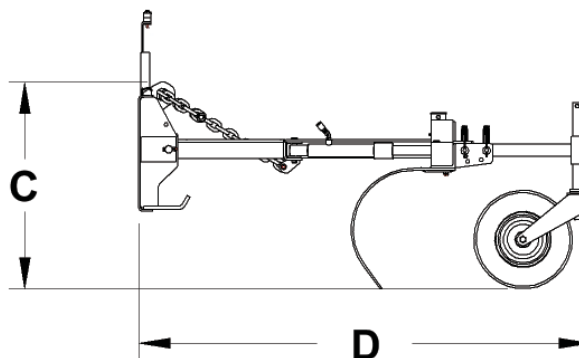

PH: (800) 747-2132  
FX: (815) 824-2620

100 East Lee Road  
Lee, IL 60530  
United States of America

www.paladinbrands.com

F-GR 0609-1

 BRADCO

 FFC

 HARLEY

 MAJOR

 MCMILLEN

 SWEEPSTER

PALADIN LIGHT CONSTRUCTION